

Training at PDSVISION

Training is one of the best investments a company can make; it is not a huge expense, it creates a better quality of work, it creates efficiency and it is fun! PDSVISION is proud to be a Certified Platinum Training Provider of PTC courses.

Whether you are a first-time or an experienced user we offer suitable training for your needs. Greater knowledge contributes to increased efficiency and higher quality of work.

Arbortext IsoDraw with CADprocesses

Course Length: 2 Days

Audience: Authors, editors, and illustrators of technical information.

Course Description:

In this course, you will learn basic and advanced drawing operations of Arbortext IsoDraw. This course emphasizes hands-on experience, interaction between student and instructor, and a solid foundation in the essential drawing skills and commands needed to produce quality technical illustrations for publications. You will learn how to open, save, and close new and existing documents.

You will also learn how to project geometry from one plane to another, and learn how to use the perspective and isometric tools. You will learn how to draw and view entities, understand 3-D projections, moves, and rotation.

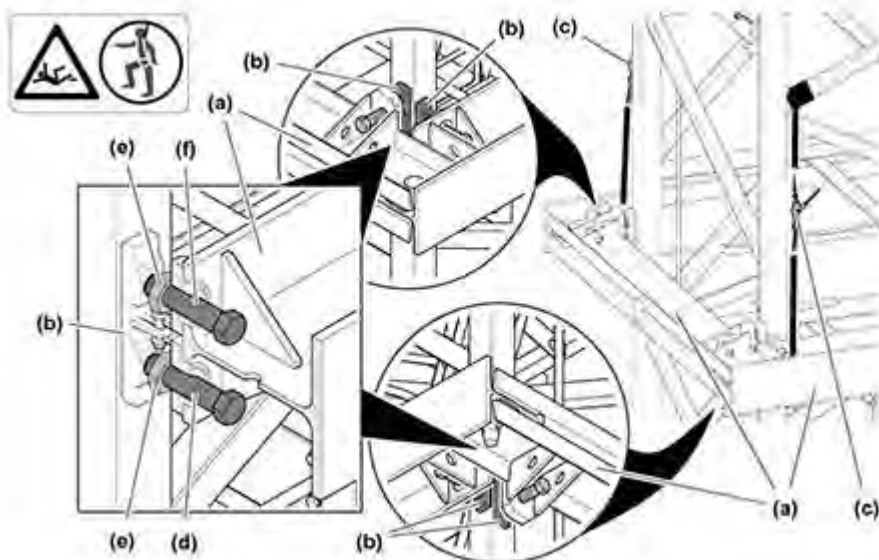

Course Content:

The course is divided into 10 modules covering the most common features and functions of Arbortext Isodraw CADProcess. Each day a certain amount of modules are presented and exercises based on information in the modules are performed.

Day 1 – 2D

- Module 1 - Get to know the User interface
- Module 2 - Draw in IsoDraw, use tools and advanced 2D features
- Module 3 - Use the library/create template
- Module 4 - Create callouts/BOM balloons in IsoDraw

Day 2 – 3D

- Module 6 - Get to know the 3D features
- Module 7 - Open 3D models
- Module 8 - Scale, move, transform, explode your 3D model
- Module 9 - Convert 3D model to a 2D illustration
- Module 10 - Use object information/structure from the 3D mode